

HH SERIES

# DEAD LIFT HOIST



The Galfab Dead Lift cable hoist utilizes the two rear flange rollers as well as a center cable roller to pull the container straight up and winch onto the hoist frame. This hoist is best utilized in tight spaces and is also available in an extendable tail option.

# THE GALFAB ADVANTAGE



## Outboard Supported Side Rollers

Greasable Roller shaft is removable with two bolts for ease of replacement and maintenance.



## Lift Cylinder

Lift Cylinder Two lift cylinders utilize a 2 1/2" shaft.



## Heavy Duty Rear Rollers

Rollers increase the life of your hoist and gives you added support to the long sills of your container.



## Front Stop

Front Stop Durable stops made with heavy duty 1-1/2" plate steel.

# STANDARD FEATURES

- 8" x 4 x 1/2" Main Frame Tube
- 3" x 2" x 1/4" Sub Frame
- 2 1/2" Diameter Rear Hinge
- All Working Points Greaseable
- Pintle Ready Apron
- 1" Spring Loaded Container Locks
- 2 1/2" Diameter Lift Cylinder Shafts
- Interchangeable 10" Vertical and Horizontal Sheaves
- 3/8 inch x 3 inch Winch Cylinder Rod Covers
- 6 Inboard and Outboard Supported Outside Rollers
- Container Long Sill Supports on Rear of Hoist Mainframe
- Heavy Duty Rear Guide Rollers
- 48 Gallon Oil Reservoir with sight and Temperature Gauge

- 25 Micron Filtration
- Inside and Outside Controls
- LED Lighting System
- Choice of Forward or Reverse Mount Single Stage or Telescopic Lift Cylinders
- 7/8" Cable with Deadlift Knuckle Hook Link
- Front Mount Pump
- Hoist Up Warning Light
- Sealed Wiring System
- Hoist Up Alarm
- Backup Alarm

# OPTIONAL FEATURES

- Behind Cab and Oversize Oil Tanks
- Tool Boxes
- Auxiliary Stops
- Poly or Steel Fenders
- Aluminum Fenders
- Tarping Systems
- Hooker Hold On Systems
- Ratchet Tie Down Straps

- PTO
- Rear View Camera Systems
- Work Lights
- Onboard Scale Systems
- Drop Shaft
- Integrated hydraulics can be used, if hydraulic tarping system is used



**"The Hooker"**  
Container Securement  
System



**Auxillary fold down  
stops**



**Hydraulic Reservoirs**



**Tool Boxes**



**Poly, Steel & Aluminum  
Fenders**

Shop all replacement parts at:

**Galfab.com**



# HH SERIES MODELS

Model	Rated Capacity	CT	Length	Dump Angle	Up (sec)*	Down (sec)*	On (sec)*	Off (sec)*	Lift Cylinder	Winch Cylinder	Container Length	Apx Weight lbs
HH50174S072	50,000	174"	19'	47	30	13	46	37	6" - 4 1/2" X 74 1/2"	7" - 3" X 81 1/2"	18' TO 20'	7,500
HH50174T121	50,000	194"	19'	47	43	10	46	37	6" - 5 - 4" X 121"	7" - 3" X 81 1/2"	18' TO 20'	8,300
HH50194T121	50,000	194"	20' - 8'	47	43	10	46	37	6" - 5 - 4" X 121"	7" - 3" X 91 1/2"	20' TO 24'	8,500

\* Cycle Times are Factory developed and controlled by PTO output, oil viscosity, human and mechanical efficiency, and may vary accordingly.

CAUTION: This Equipment Should be Operated by Properly Trained Personnel. Improper Use, Misuse, or Lack of Maintenance Could Cause Injury to Persons or Property. Photos used in this brochure are illustrative only. We reserve the right to make changes at any time without notice. Information contained within this literature is believed to be the most accurate available at the time of printing.

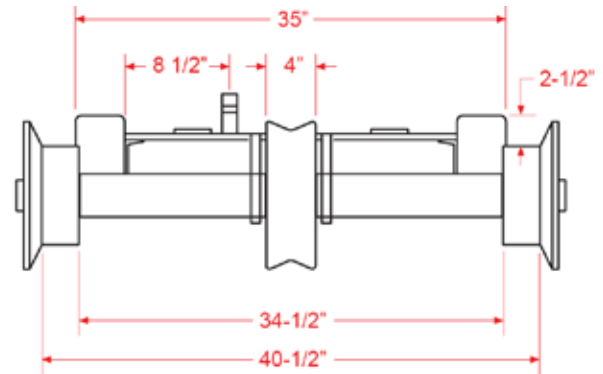
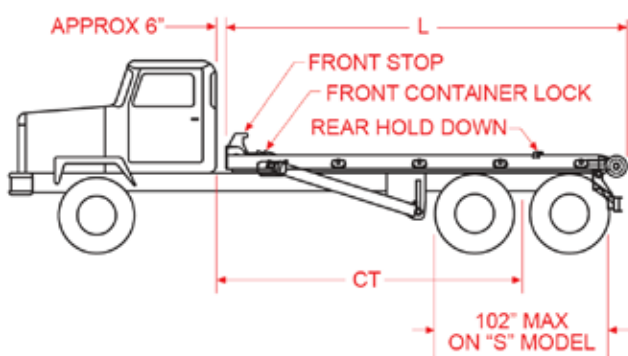

HOIST FRAME DETAILS

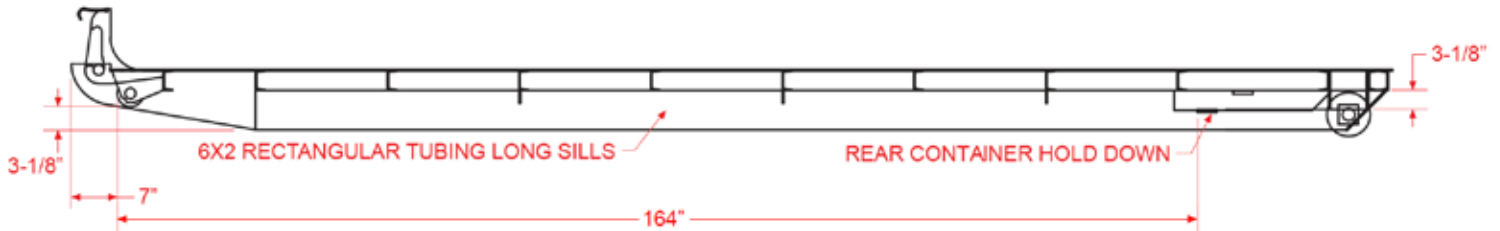

OUTSIDE RAIL CONTAINER REQUIREMENTS