

ISUZU NRR
19,500 GVW

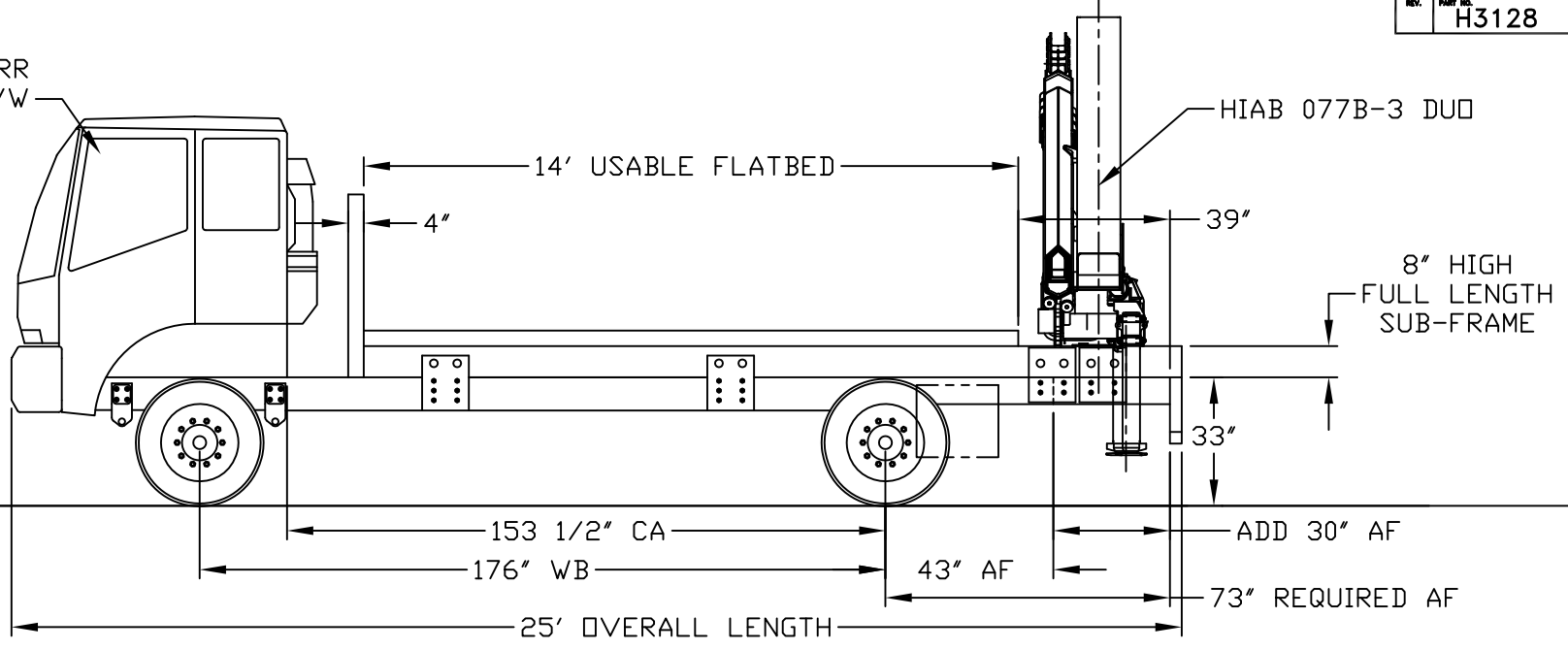

TRUCK, HIAB CRANE & ACCESSORIES WEIGHT DISTRIBUTION, NO PAYLOAD.	
TOTAL WEIGHT ON FRONT AXLE	= 4,710 LBS.
TOTAL WEIGHT ON REAR AXLE	= 9,320 LBS.
FRONT AXLE WT. PERCENTAGE	= 34 %
REAR AXLE WT. PERCENTAGE	= 66 %
GROSS VEHICLE WEIGHT	= 14,030 LBS.

TRUCK, HIAB CRANE & ACCESSORIES WEIGHT DISTRIBUTION, WITH PAYLOAD.	
TOTAL WEIGHT ON FRONT AXLE	= 6,260 LBS.
TOTAL WEIGHT ON REAR AXLE	= 13,240 LBS.
FRONT AXLE WT. PERCENTAGE	= 32 %
REAR AXLE WT. PERCENTAGE	= 68 %
GROSS VEHICLE WEIGHT	= 19,500 LBS.
PAYLOAD EVENLY DISTRIBUTED	= 5,470 LBS.

TRUCK SPECIFICATIONS	
TRUCK MODEL	= ISUZU NRR
WHEELBASE	= 176"
CAB TO AXLE	= 153 1/2"
AXLE-TO-FRAME	= 43" EXISTING
AXLE-TO-FRAME	= 73" REQUIRED
FRONT CURB WEIGHT	= 4,361 LBS.
REAR CURB WEIGHT	= 2,500 LBS.
FRONT G.A.W.R.	= 7,275 LBS.
REAR G.A.W.R.	= 13,660 LBS.
YIELD STRENGTH OF EACH FRAME RAIL	MINIMUM SECTION MODULUS REQUIRED
44,000 P.S.I. YIELD	= 23.73 in. ³
MINIMUM RBM/RAIL OF 1,044,000 IN-LBS	

NOTES:

FULL LENGTH SUB-FRAME REQUIRED.
 8"x3"x3/8" RECT. TUBING (ON TOP OF FRAME RAIL)
 6"x3"x3/8" RECT. TUBING (CROSSMEMBERS EVERY 3 FT.)
 4" OUTRIGGER EXTENSIONS REQ'D FOR GROUND PENETRATION.
 CURB WEIGHTS ARE FROM IMPORT INDEX.
 FLATBED WEIGHT WAS ESTIMATED.

TRUCK RUNS IN US (RULES FOR MOST STATES).
 7,275 LBS. ALLOWED ON FRONT AXLE GAWR.
 13,660 LBS. ALLOWED ON REAR AXLE GAWR.
 19,500 LBS. ALLOWED FOR GROSS WEIGHT.

NOTICE:
 THE DRAWING PURPOSE IS TO INTRODUCE A GENERAL CONCEPT OF A PROPOSED IDEA.

NOTICE:
 THIS WEIGHT DISTRIBUTION IS BASED ON ESTIMATED WEIGHTS AND IS ONLY AS ACCURATE AS THOSE ESTIMATES. ACTUAL WEIGHTS MAY CHANGE THE RESULTS OF THIS WEIGHT DISTRIBUTION.

Hiab
 Hiab, Inc.
 12233 Williams Road
 Perrysburg, Ohio 43551
 Tel (419) 482-6000
 Fax (419) 482-6001

Tolerances - unless otherwise noted.
 Tolerances are in inches
 2-PLACE ±.000..... .03
 3-PLACE ±.000..... .015
 ANGULAR ± 1/16"
 FRACTIONAL ± 1/16"
 Break all sharp corners unless otherwise specified.

THIS PROPERTY AND ALL INFORMATION THEREIN IS THE PROPERTY OF HIAB, INC., 12233 WILLIAMS RD., PERRYSBURG, OHIO 43551 AND IS CONFIDENTIAL. IT MUST NOT BE MADE PUBLIC OR COPIED. THIS DRAWING IS LOANED TO RETURN UPON DEMAND AND SHALL NOT BE USED DIRECTLY OR INDIRECTLY IN ANY WAY DETRIMENTAL TO OUR INTERESTS. OUR PRIOR SPECIFIC APPROVAL IS REQUIRED FOR EXPOSURE OF THIS DRAWING TO OTHERS FOR ANY PURPOSE.

Next Assy.
 Dwg/Cad file no. 077 / SALES

Drawing Title: HIAB 077B-3 DUO CRANE			
Project Name: SALES LAYOUT			
Drawn by: J W	Date: 8-10-15	Size:	Part No.:
Approval:	Date Approved:	Scale:	unit wt. Eng. Job no.: